

UNIQUE SOLUTIONS MADE BY THE SPECIALIST



Joh. Heinr. Bornemann GmbH

Industriestraße 2
31683 Obernkirchen
Germany

Fon: +49 5724 390-0
Fax: +49 5724 390-290
info@bornemann.com
www.bornemann.com



Germany – Headquarter

USA

Bornemann Pumps Inc.
P.O. Box 1769
Matthews, NC 28106
USA
Fon: +1 704 849 86 36
Fax: +1 704 849 86 37
info.usa@bornemann.com

CANADA

Bornemann Inc.
320 441, 5th Avenue S.W.
Calgary, Alberta
Canada T2P 2V1
CANADA
Fon: +1 403 668 05 52
Fax: +1 403 262 40 73
info.cdn@bornemann.com

ARGENTINA

Bombas Bornemann S.R.L.
Armenia 2898
B1605CDP Munro
Prov. Buenos Aires
ARGENTINA
Fon: +54 11 475 680 08
Fax: +54 11 475 655 41
info.ar@bornemann.com
www.bornemann-ar.com

CHINA

**Bornemann Pumps & Systems
(Tianjin) Co., Ltd.**
Jinbin General Building No. 6,
No. 45 Muning Road
TEDA, Tianjin
P. R. China 300457
CHINA
Fon: +86 22 662 978 00
Fax: +86 22 253 267 99
info.cn@bornemann.com
www.bornemann-cn.com

SINGAPORE

Bornemann Pumps Asia Pte. Ltd.
25 Intern. Business Park
German Centre, # 04-08
Singapore 609916
SINGAPORE
Fon: +65 656 167 82
Fax: +65 656 167 84
info.sq@bornemann.com



Spin Pompen

www.spinpompen.nl
Onze ervaring uw winst

BORNEMANN PUMPS FOR FOOD, PHARMACEUTICALS AND MORE

THE STANDARD IN SANITARY PUMPS

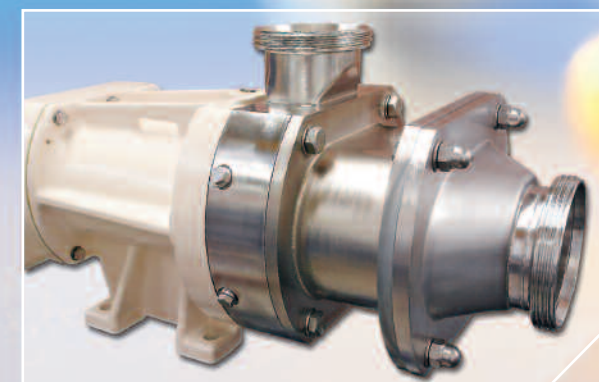

MODULAR SYSTEM

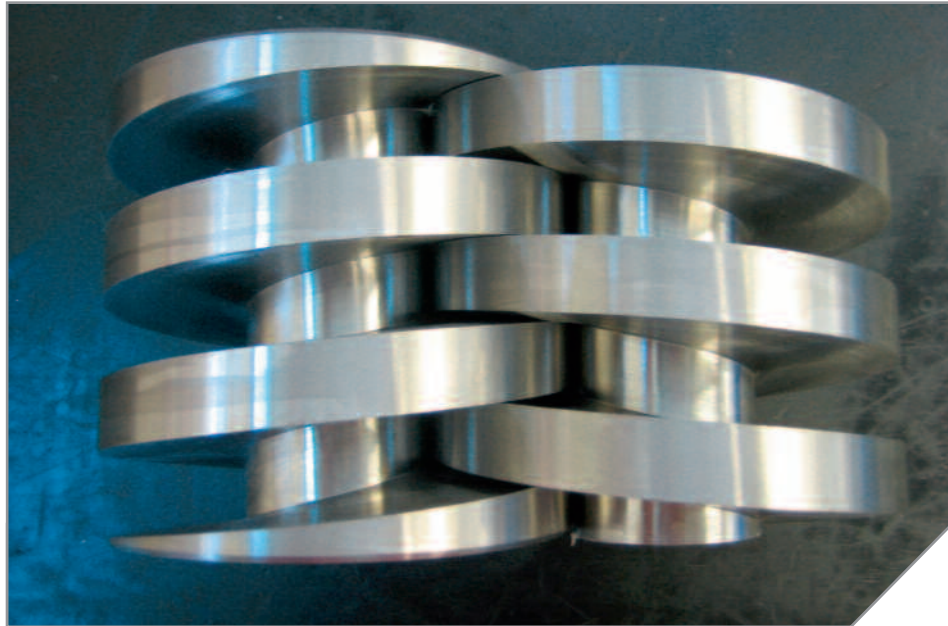

Bornemann SLH twin screw pumps are single-flow and self-priming. Two contact-free intermeshing screws and the pump housing form closed chambers that, according to the direction of rotation, constantly move towards the pressure discharge end of the pump. This axial system enables cautious, low-pulsation conveyance. It protects the media and maintains size, surface and visual integrity of the products.

The 2-in-1 principle conveys and cleans in one pump. Due to the wide range of pump speeds – up to a maximum of 3,600 rpm, process cycles as well as CIP and SIP procedures are possible with just one pump.

The advantages are obvious: no need for a CIP pump or the associated piping, valve and MSR technology. It saves valuable space and reduces your investment costs. The conveyed material passes through the entire pump which enables excellent cleaning and hygienic results. The Bornemann SLH pump is EHEDG and 3A certified.

2-in-1

CONVEY AND CLEAN WITH ONE PUMP

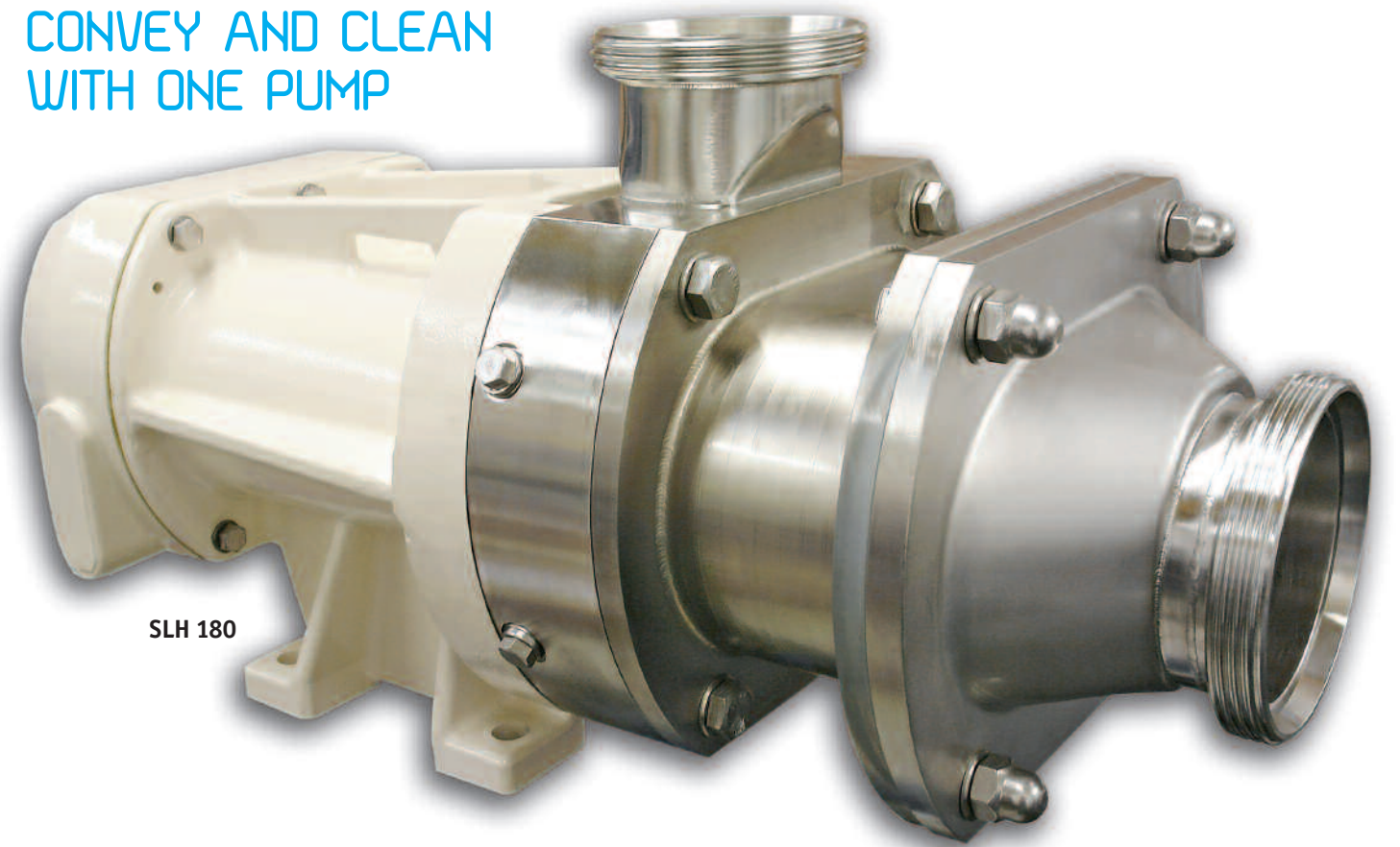

SLH 180

- Self-priming down to a vacuum of less than -0.8 bar when the pump is filled
- Large range of speeds, from below 100 up to 3,600 rpm, make it possible to convey with one pump and also use it as a conveying aggregate
- Excellent cleaning and hygienic properties
- Abrasion-free
- Can be adapted for nearly any medium
- Low-pulsation conveyance
- Dry running protection
- Designed for reverse flow capabilities

IMPRESSIVE SPECTRUM OF PERFORMANCE FEATURES



Receipt of goods with mobile pump



Dairy products conveyance

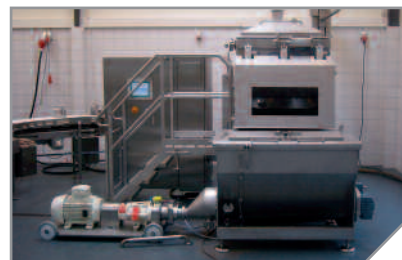

Melted cheese conveyance



Dairy products conveyance



Model SLH pump



Conveyance of high viscous products

THE SUM OF MANY ADVANTAGES

SIX REASONS TO BELIEVE

Bornemann SLH pumps provide you with a range of convincing advantages that together result in the highest possible cost and production efficiency.

Using a modular system, Bornemann offers three pump sizes and different screw sets that cover a conveyance range of 1 m³/h to 180 m³/h with a unit size up to 40 mm diameter. The different screw sizes make it possible to handle a wide range of flow capacities with the same viscosities, operating pressures and rotation speeds.

Quick and easy change of the media.

1 CIP and SIP – easy cleaning and sterilization

2 High suction performance for more production efficiency

3 Smooth and pulsation-free handling for sensitive products

4 Top resistance to wear leads to safe production and long lifetime

5 Handles the widest range of viscosities

6 Adaptable to the medium – flexible implementation

TECHNICAL DATA

PERFORMANCE DATA

SLH 80 | SLH 125 | SLH 180

Output Capacities:
up to 180 m³/h (792 gpm)

Differential Pressures:
up to 16 bar (232 psi)

Pump Speed: max. 3,600 rpm

Viscosity: max. 100,000 cst

Direction of Operation:
reversible operation possible

Flange Connections:
dairy connection according to DIN 11851, aseptic connection according to DIN 11864, other connections varieties upon request

Heating medium: various

Heating temperature:
max. 130°C (266°F)

Cleaning temperature:
up to 140°C (284°F)

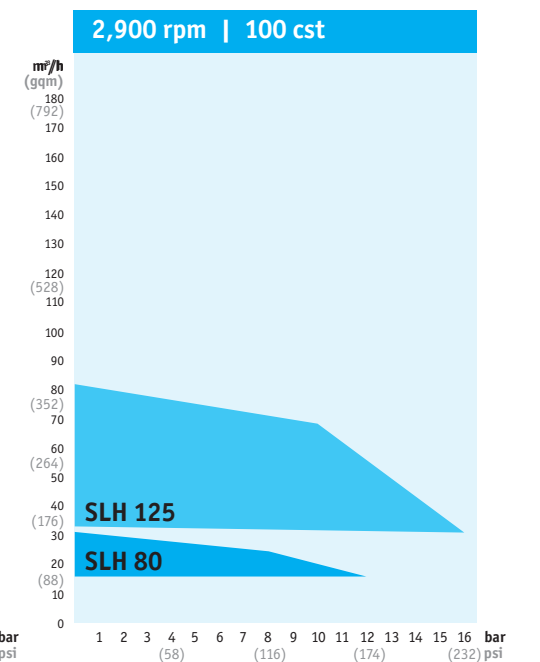
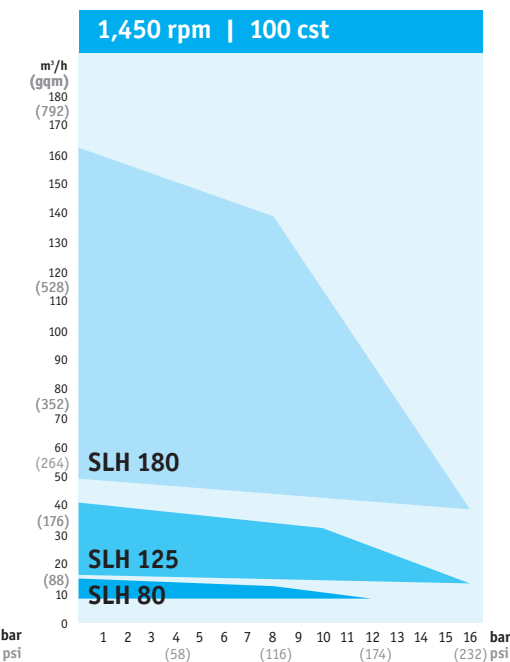
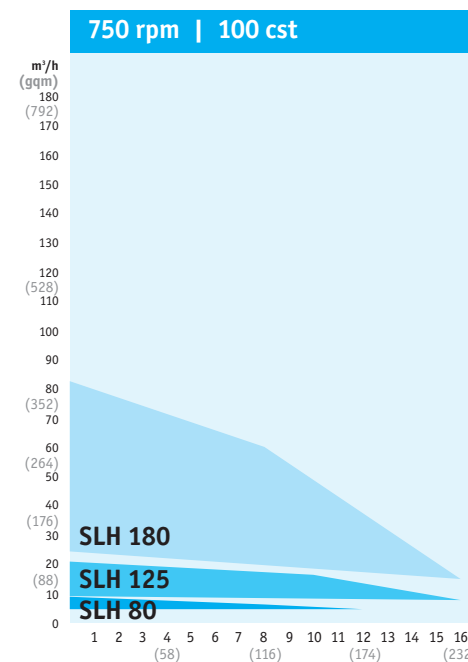
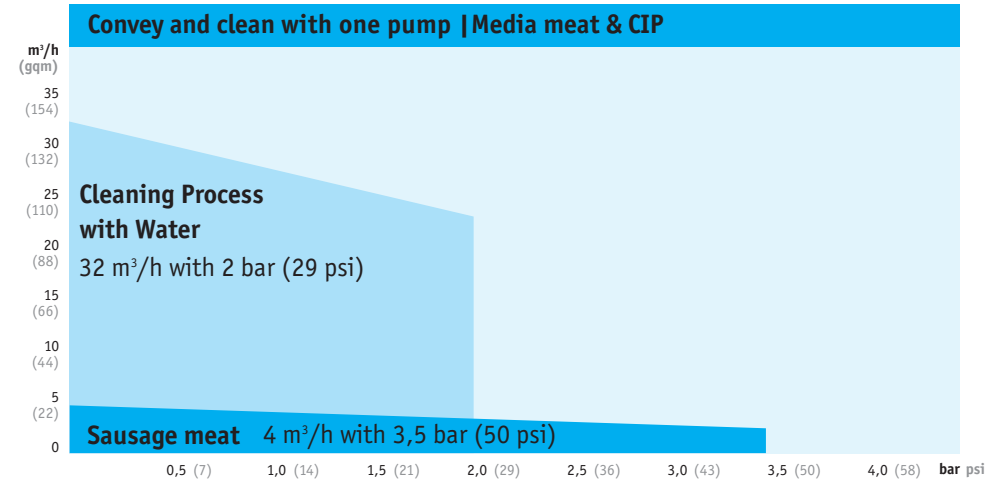

CONVINCING PERFORMANCE



SLH 125



Low abrasion conveyance of toothpaste



Sausage meat conveyance



Cheese conveyance



Yeast conveyance



Beer conveyance

AN EXEMPLARY CONCEPT

SLH pumps feature no metal-to-metal contact between the pump screws and the housing. This enables the conveyance of non-lubricating or corrosive and contaminated materials. As the pump rotates, the intermeshing of the two screws along with the pump housing form chambers. These chambers fill with the pumped fluid and move it from the suction side of the pump to the higher pressure discharge side of the pump.

Very flexible: The pump is designed to allow for reverse flow by simply changing the shaft direction. The

suction becomes the discharge and vice versa, all without any modifications to the pump.

Bornemann SLH pumps come with a rotation speed of up to 3,600 rpm. This range makes not only process cycles as well as CIP and SIP procedures possible with

just one pump, but also increases flexibility of use with varying viscosities, temperatures, operating pressures or

other important criteria where efficient and profitable production are the objective.

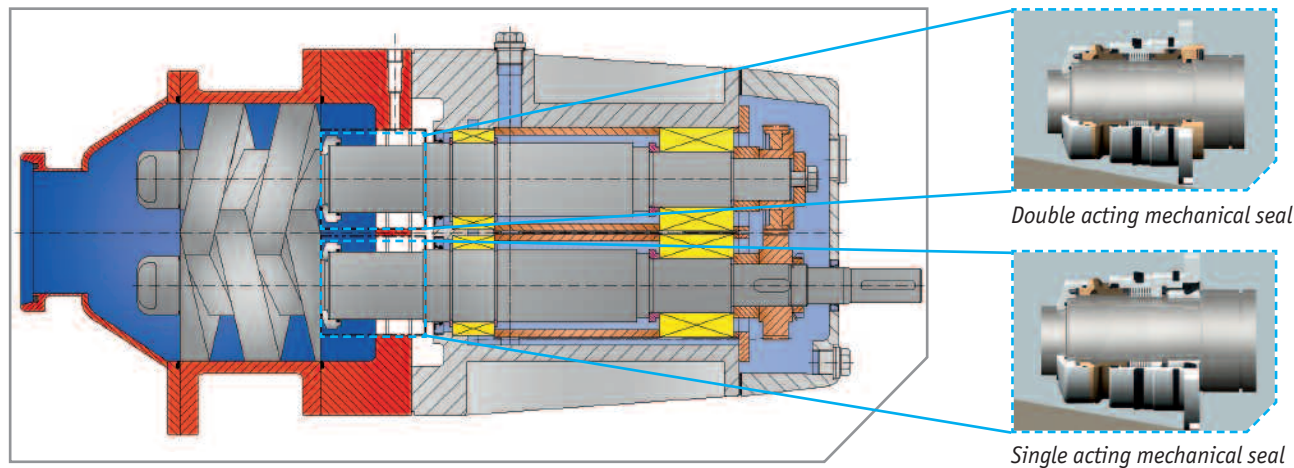
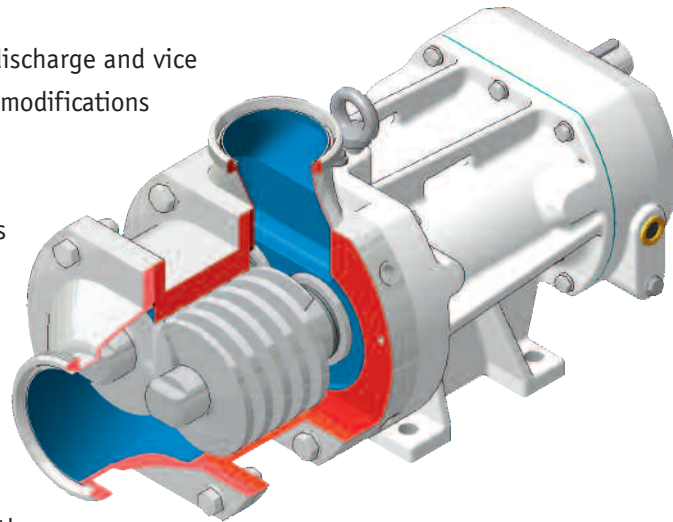

BORNEMANN PUMPS FOR FOOD AND MORE...

BEVERAGE INDUSTRY

- Juices
- Concentrates
- Syrups
- Wines
- Sparkling wine
- Malt extract

CONVENIENCE

- Oils & greases
- Soups
- Sauces
- Dressings
- Ketchup
- Porridge
- Dough
- Marmalade
- Mousse
- Honey
- Spreads
- Salads
- Meats
- Fish
- Delicacies
- Baby food
- Products in chunky form

DAIRY PRODUCTS

- Yoghurt
- Quark
- Single cream
- Butter
- Cream
- Pudding
- Desserts
- Concentrates
- Melted cheese
- Curds

SWEETS

- Chocolate
- Cream
- Fudge
- Molasses
- Liquid sugar
- Raw mixtures
- Fillings

MEAT PRODUCTS

- Sausage meat
- Sausage prep
- Pet food

PHARMACEUTICAL INDUSTRY

- Cosmetics
- Raw materials

...AND WHAT INDUSTRY DO YOU CALL HOME?



Beverage industry



Convenience

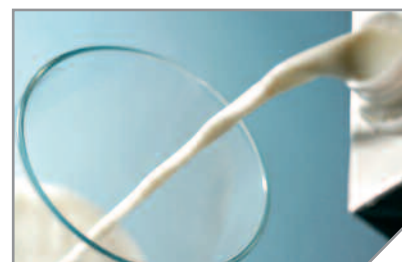

Dairy products



Sweets



Meat products



Pharmaceutical industry